

## Magnetic sensors

### I- Basic principle of a magnetic sensor

1°- REED switches magnetic sensors

2°- Electronical sensors

- a) **HALL effect sensors**
- b) **Magneto-resistance sensors**

### II- Permanent magnets

### III- Operating mode

### IV- Main detection modes

### V- Applications and solutions by celduc<sup>®</sup> relais

1°- Level sensors

2°- Presence sensors

- a) **Door / Window**
- b) **Gates / Stores**
- c) **Sensors for layout on PCB**

3°- Passage sensors

- a) **Lifts**
- b) **Cylinders position**
- c) **Scraper**

4°- Speed sensors

5°-Safety sensors

6°- Special applications

- a) **ATEX Sensors (Explosive ATmospheres)**
- b) **Household electrical appliances**
- c) **Agriculture**

7°- Special customer products

Sensors are today more and more popular and can be found in many different applications : position, presence, fluid level, speed, safety.....and in sectors as various as industry, white goods, automotive and so on.

Besides mechanical switches, some technologies are available with their own characteristics :

**a) Inductive sensors** – Principle : using a magnetic circuit tuned in order to react when a metal part is present next to their active side, hence detecting with no contact the position of a metal part.

These sensors are widely used in machine tools for position, presence or counting operations. Generally speaking, detection distance is proportional to the size of the sensor. Metal chips can alter the sensor operation.

**b) Capacitive sensors** - Based on an electronic principle where an electric field is produced on the active side, the sensor will detect the capacitor value variation caused by the presence of the non metallic part to be detected. In general these sensors are rather big.

**c) Optical sensors** - Based on a light emitting source with a receiver or on light reflection, the cut of the light beam will be detected.

Main application is light gates.

Lining up light cells may be difficult to do and presence of dust can alter the sensor function.

**d) Ultrasonic sensors** - Based on an ultrasonic source and receiver in the same device, the sensor will measure the time needed for an ultrasonic pulse to come back after reflection on the target. Presence of an object will alter this time and object will be detected. These sensors are big and expensive.

**The alternative is magnetic sensors** that often show many advantages.

**celduc<sup>®</sup> relais is a specialist in magnetic sensors.**

It is based on an electronic or mechanical principle detecting a magnetic field.

It can detect with no contact the presence of a magnet and gives an ON-OFF signal to the control system.

celduc<sup>®</sup> relais has also developed flow sensors with analogue output 4 to 20 mA, giving an output proportional to the flow.

## I- Basic principle of a magnetic sensor

### 1°- REED switches magnetic sensors

At the beginning, magnetic sensors use a REED switch made of ferro-magnetic blades sealed in a glass bulb filled with an inert gas.

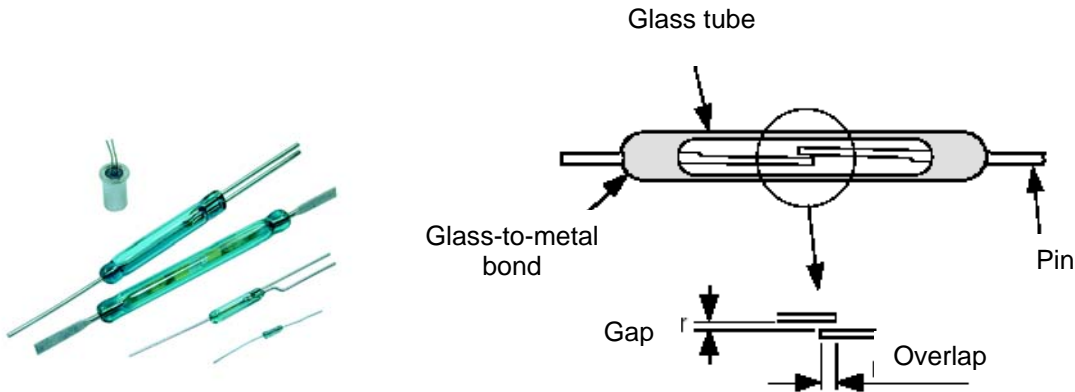

**There are two main different types of Reed Switches :**

- A Form : Normally open contact**
- C Form : Reversing contact (NO + NC)**

REED switch is the base for magnetic sensors.

Main advantages are the following :

- No power supply is needed. There is no power consumption when the switch is OFF and it provides a real galvanic insulation. There is no voltage drop at ON state.
- It can be used in harsh environment : dust, water, ...
- Distances for detection can be very large. This depends on the REED switch sensitivity, but mainly on the magnet.
- Very price effective compared to all of the existing technologies.

### 2°- Electronical sensors

There are two other principles used in magnetic sensors :

#### **a) HALL effect sensors**

This is based on the fact that a voltage will appear on both sides of a bar when there is a current in this bar and when the bar is in a magnetic field perpendicular to the bar (see drawing).

The voltage created is called « HALL voltage » and is directly proportional to the magnetic field and current in the bar.

These sensors are sensitive to temperature variations, but electronic devices can now compensate this drawback.

There are several types of HALL effect cells available, giving an ON-OFF output as follows :

→One pole cell : sensitive to a magnetic field in one direction only

→Two-pole cell : On-state with a positive magnetic field and Off-state with a negative magnetic field

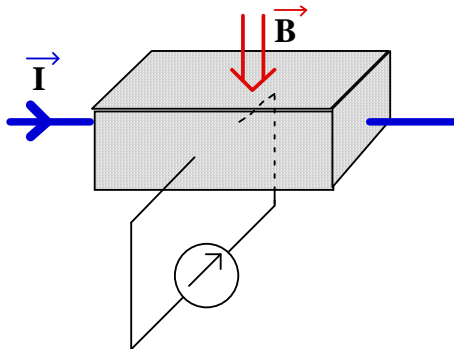

**Hall voltage**  
 $V = k.B.I$   
(K = Hall constant)

### **b) Magneto-resistance sensors**

Based on the resistance variation of conductive material that varies with the orientation of the magnetic field.

The magnetic field alters the resistivity of materials.

As variations are small it is necessary for a good detection to have a rather high current.

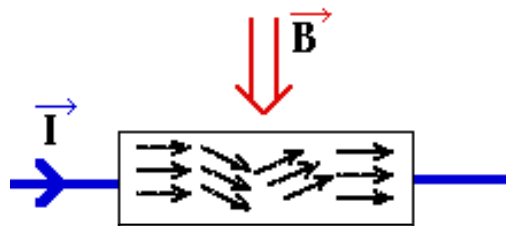

## **II- Permanent magnets**

Many sorts of magnets are available but the three main types used with magnetic sensors are the following :

**a) FERRITE** Operating temperature from  $-40$  to  $+150^{\circ}\text{C}$ . Important recoverable losses with temperature ( $-0.2\%$  per  $^{\circ}\text{C}$  above  $20^{\circ}\text{C}$ ). Can withstand de-magnetising fields. Low price.

**b) ALNICO** Very high operating temperature up to  $400^{\circ}\text{C}$ . Low recoverable losses with temperature ( $-0.02\%$  per  $^{\circ}\text{C}$ ). Very sensitive to de-magnetising fields (can be de-magnetised just by rubbing; low coercive field). Medium price level.

**c) Rare Earth** Operating temperature of  $180^{\circ}\text{C}$  can be reached today. These magnets are very powerful. Medium recoverable losses with temperature ( $-0.1\%$  per  $^{\circ}\text{C}$ ). Not sensitive to de-magnetising fields. With prices that have been significantly reduced, these magnets have the additional advantage to be very small in size.

### III- Operating mode

REED switches as well as magneto-resistance will be activated by positive or negative field lines.

One-pole HALL-effect cells will operate only with negative field lines.

Two-pole HALL-effect will be activated by negative field lines and deactivated by positive field lines.

Operating diagram according to magnet movement and sensor, and type of technology:

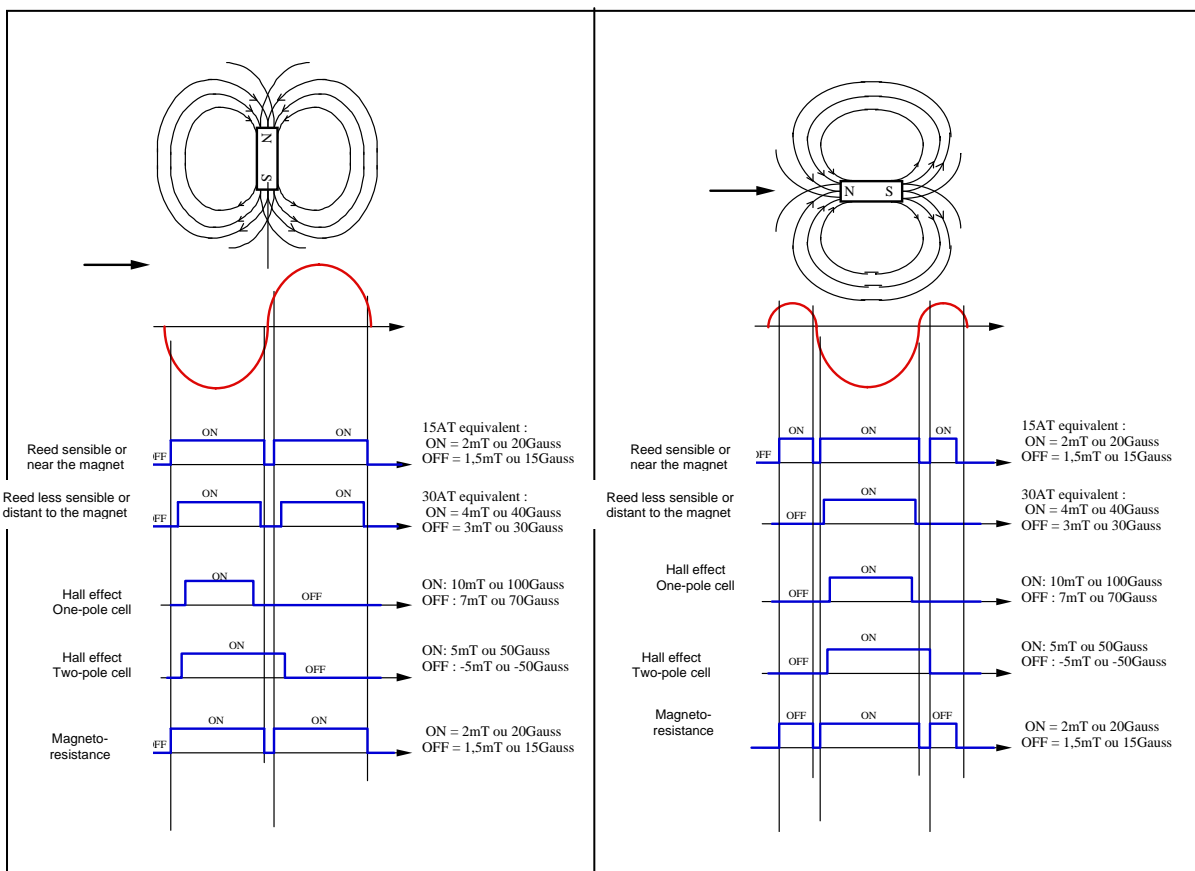

## IV- Main detection modes

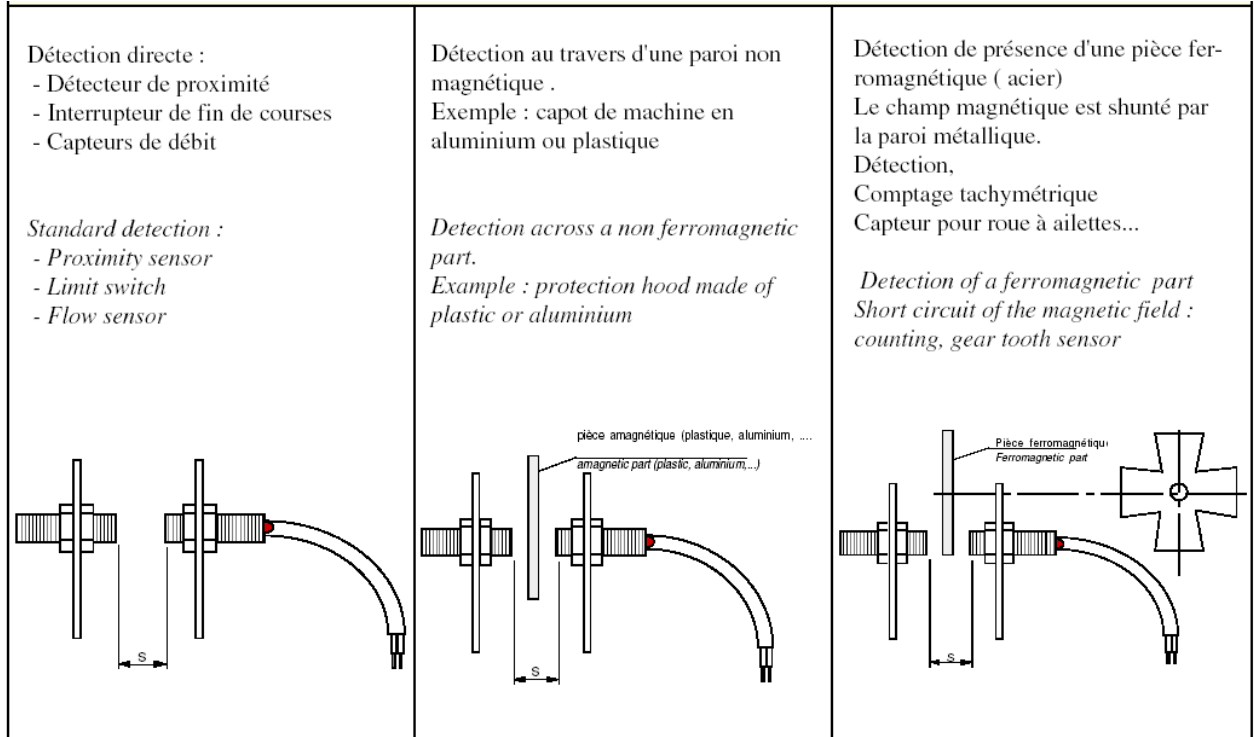

### Detection distances :

The detection distances depend mainly on the application.  
For example a REED switch 15AT and a rare earth magnet : distance > 30mm

Some applications in the aircraft industry or space industry need very accurate detection distances.

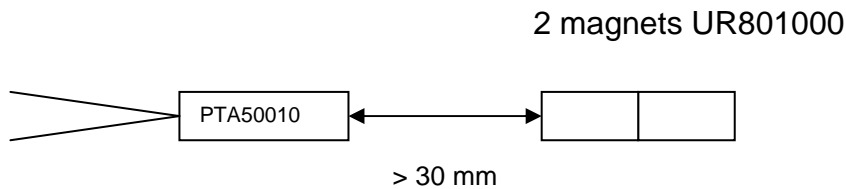

## V- Applications and solutions by celduc<sup>®</sup> relais

### 1°- Level sensors

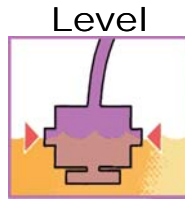

#### Working :

A float equipped with one or more magnets move with the liquid and start up, thanks its magnetic field, a Reed contact hermetically sealed situated in the axis

#### Advantages :

→One moving piece only: the float

→The Reed contact is started up thanks to a magnetic field only, without any wear

→The Reed contact is completely isolated from the liquid so there is perfectly waterproof (between sensor and liquid)

These advantages warranty to the user a safety use, allow a repetitiveness, a precision and low maintenance.

celduc<sup>®</sup> relais offers 3 types of level sensors :



**-PTF01070** : Float in polypropylene and case in PA66 Plastic / Vertical mounting / Suitable for limited place and small tank, or for any use with low prices and huge quantities

**-PTFA2015** in stainless steel / Vertical mounting / rugged / for aggressive liquids



**-PTFA3015** in PE plastic / horizontal mounting

#### Typical applications :

→Water level in coffee machines (the sensors give a signal which starts a pump to keep the necessary water's level)

→Water purifying (the sensors enable to know the level of the reserve of water)

→Medical equipments (examples: water level in sterilizer for medical instruments, ...)

→Oil / Fuel level

→Lavatories

→ Automotive industry: water level, brake fluid for ABS system, presence of water in diesel, liquid of windscreen washer ...

2°- Presence sensors

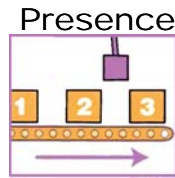

a) Door / Window

- Alarms,
- Stop of heating / air-conditioning in buildings

The sensor is fixed on the fixed part of the door / window and the magnet on the moving / opening part.



Selection criteria:

- Type of frame (space available between the fixed part and the opening part)
- Mounting,
- Cable length.

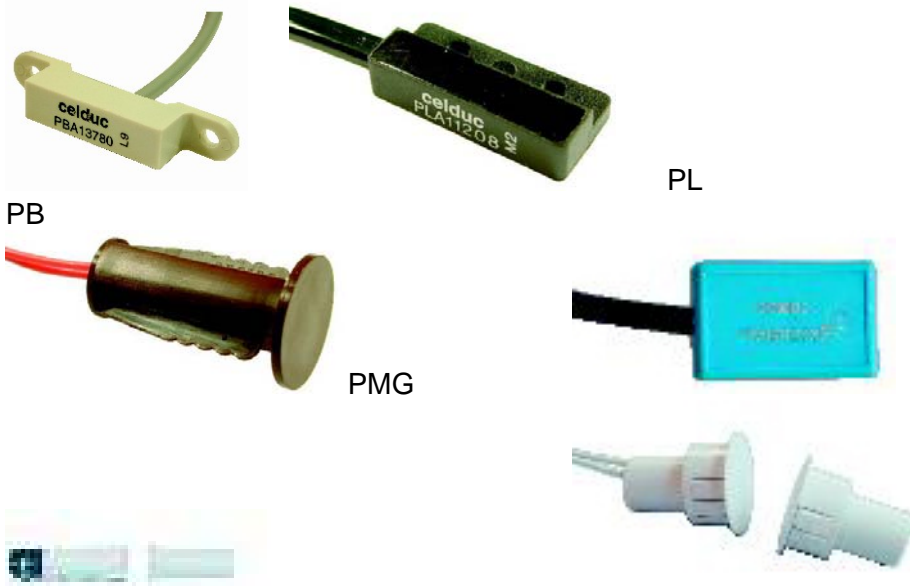

Electronical version for opening / closing of windows and doors



- LED for better adjustment
- These electronical sensors are suitable for small moves
- Insensible to shocks and vibrations
- Better life expectancy as there is less wear



### **b) Gates / stores**

- Sensor and magnet are in metallic case (resistant)
- Cable protected by a metal shaft (resistant)
- High switching power: 230VAC 50VA.

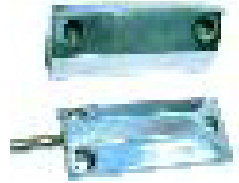

#### Typical applications:

- Industrial safety curtains
- Hard mechanical environments (cleaning with jet of water, industrial use, dusty environment)

### **c) Sensors for layout on PCB**

Sensors to be mounted directly on PCB for the detection of opening or presence. These sensors stop the working in case of opening of the case. They can be used on every electronical cards.



#### Typical applications:

- Handset of telephone (to detect the picking up or the hanging up of the phone)
- Opening of small casing
- Counting

### 3°- Passage sensors

#### a) Lifts

#### Passage

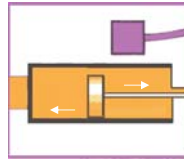

→Special case for positioning on the cabin

→REED version with 1NO or 1NC / change-over or bistable switch

→High switching power until 100 W



Thanks to the key technologies used, these sensors fulfil the standards required by the world-wide producers or by their suppliers:

- Reliability,
- Large detection distance,
- Insensitiveness to all types of pollution such as dust, grease, humidity, ...
- Shock and vibration-proof,
- IP67

#### Typical applications :

- Cabin-stop: In that case the sensor allows knowing the exact position of the cabin in order that the cabin can stop just in front of the doors
- Security in upper limit or lower limit position of the lift: two sensors are requested for this application (one for each position). They allow stopping the cabin when reaching the limited positions
- Control of the opening and closing of the doors
- Detection of the direction of the way (passage): the sensor allows knowing where the cabin comes from

### **b) Cylinders position**

In an Industrial-world where everything is automated and robotized, le manufacturing is often made by robots or complicated mechanical systems.

The main motoring element (motor, cylinder, ...) which makes the requested movement should normally restores information about its state. Most of the systems are not composed of just one movement but made up of mechanical sets linked together and to the good execution of the different steps. The robotic specialist makes sure that a command is given only after the end of the previous cycle.

This is at this stage that celduc<sup>®</sup> relais, with its own experiment in automatism, suggests solutions for detections with its range of passage sensors.

The magnet, which is a cylinder, is putted on the piston.  
The two extremely positions are detected (front and back positions) as well as the changes of state which commands the robots.

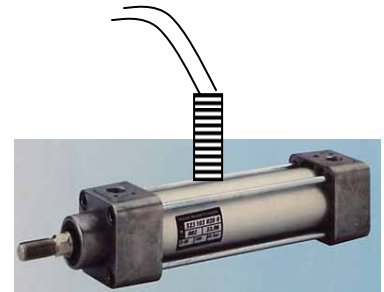

### **c) Scraper**

In this application the sensors are used to control the passage of the scraper used to clean the pipes and also to define its position and orientation.

#### Typical applications :

- Refineries
- Chemical factories



4°- Speed sensors

Speed

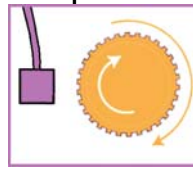

These sensors are made mainly with the Hall or magneto-resistance technologies. In that case the magnet is integrated inside the sensor and we detect a variation of the magnetic field when coming a ferromagnetic piece.

The main advantage of this technology in comparison with inductive sensors is the power to detect with precision very slim tooth (for counting applications for example).

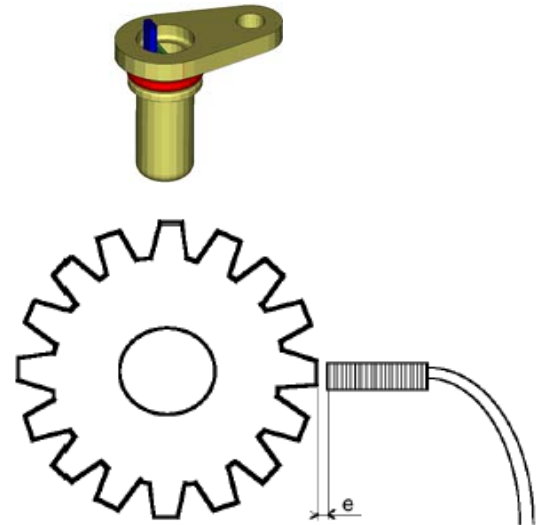

5°- Safety sensors

Safety

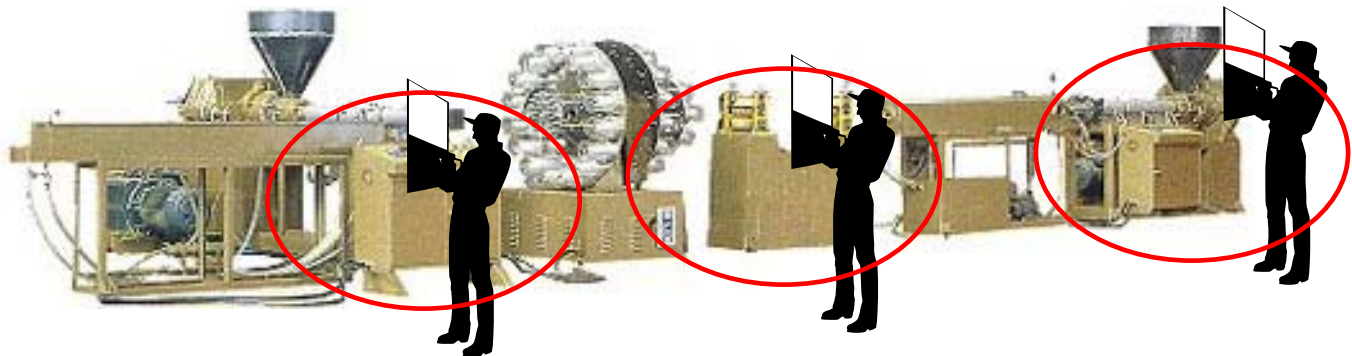

The PXS or PSS ranges are safety sensors used to give an emergency signal and / or stop dangerous machines when protective devices, machine casings or door are open.

The type of sensors used depends on the safety level of the machines.

So first the machine makers have to define the possible injuries when working on their machines and then the safety level required.

The magnet and the sensor are coded in order to reach the different level of inviolability.

**How to define a safety level ?**  
(according to the EN954-1 standard)

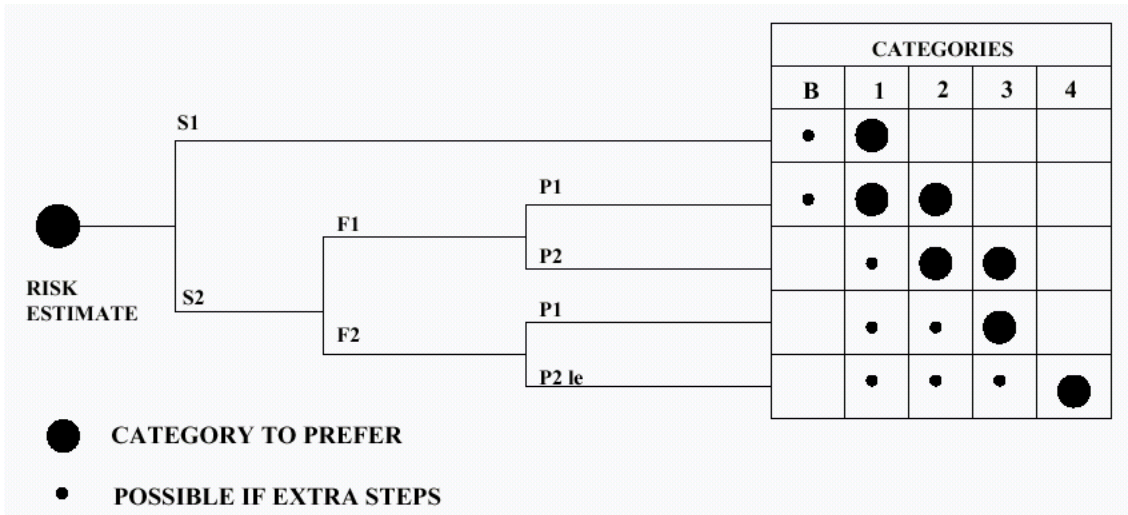

<b>S</b>	<b>Risk Estimate</b>
S1	Light injuries
S2	Bad injuries
<b>F</b>	<b>Frequency</b>
F1	Low frequency
F2	High frequency
<b>P</b>	<b>Possibility of being anticipated</b>
P1	Fault can be detected
P2	No detection possible

### How to define which sensor to use ?

→ We have 4 ranges of safety sensors with different types of contacts to get the safety of the machine :

Reminder : -“1 O” means 1 contact Open  
-“1 C” means 1 contact Closed

- **1O** : PSA60010
- **1O + 1C** : PXS59010, PXS59150, PSS59050, PSS59150
- **2O** : PXS79020, PXS79120, PXS79150, PXS79010, PXS79110, PSS79050, PSS79150
- **2O + 1C** : PXS70150, PXS10350

The use of the control devices is required for the monitoring of magnetic safety switches for the categories 2 – 3 and 4.

### → The type of sensors you will use depends on the safety level required :

- Category 1 : you have to use 1x “**1O**” safety sensor / PSA60010 (only for alternative current)
- Category 2 : you have to use 1x “**2O**” safety sensor with 1 contact connected to the control device
- Safety level 2+ : you have to use 1x “**2O**” safety sensor with 2 contacts connected to the control device
- Safety level 3 or 4 : you have to use 2 x “**1O + 1C**” safety sensors with 1 contact of each sensor connected to the control device
- Sometimes, to reach level “4+”, you have to use two 2x “**1O + 1C**” with 2 contacts of each sensor connected to the control device. But these applications are not used very often as you have to test the door before using the machines.

Our safety sensors should be associated to their suitable magnet : P2000100 for the PXS range, P3000100 for the PSS range et P6250000 for PSA60010.



## 6°- Special applications

### a) ATEX Sensors (Explosive ATmospheres)

These sensors can be used in:

- Petrol stations
- Chemical factories



### b) Household electrical appliances



Washing machines / Dryers

#### Typical applications :

- Stop of the drum when the door is open (for washing machines with top loading)
- Speed sensor

### c) Agriculture

#### Typical applications :

- Position of the gear lever
- Seeder : counting of the caliber seeds
- Release of sound or lighting warning
- Level of the silo



7°- Customised products

**We are the expert !!**

There are numerous special customer applications in all sectors of activity.

Thanks to our 30-year experience in key technologies that we use in our products we can create the best suitable products for your application.



Potentiometric scale (level)  
(Application : postal sorting)



Speed sensor integrated into ball  
bearing : speed counter, kilometers, ...